

Internal Serial PC Watchdog™ User's Manual

Berkshire Products, Inc.
PO Box 1015
Suwanee, GA 30024

Phone: 770-271-0088
FAX: 770-932-0082

<http://www.berkprod.com/>
<http://www.pcwatchdog.com/>
email: sales@berkprod.com

Rev: 2.07
© Copyright 1999, 2000, 2001

PC Watchdog is a registered trademark of Berkshire Products

Table of Contents

1. INTRODUCTION	1
2. OPERATION	2
3. INSTALLATION OF SUPPLIED COMPONENTS	3
3.1 BASIC INSTALLATION	3
3.2 SECONDARY RESET OPTION	3
3.2.1 SECONDARY RESET OPTION DIAGRAM #1	4
3.2.2 SECONDARY RESET OPTION DIAGRAM #2	5
4. DIP SWITCH SETTINGS	6
4.1 MODE SWITCHES - SW1, SW2 & SW3	6
4.1.1 MONITOR MODE - SW1	6
4.1.2 COMMAND MODE - SW2	6
4.1.3 RING MODE - SW3	7
4.2 POWER ON DELAY (POD) - SW4	7
4.3 OVER-TEMP RESET - SW5	7
4.4 TIMEOUT COUNT / RING COUNT - SW6, SW7, & SW8	8
5. COMMAND MODE OPERATION	9
5.1 COM PORT SETTINGS	9
5.2 COMMAND FORMATS	9
5.3 RESPONSE FORMAT	10
5.4 WATCHDOG COMMANDS – REVISION B BOARDS	11
5.4.1 RESET PC NOW - [0x20]	11
5.4.2 RESET PC IN 10 SECONDS - [0x21]	11
5.4.3 OVERRIDE POWER-ON-DELAY - [0x24]	12
5.4.4 DISABLE WATCHDOG - [0x28]	12
5.4.5 ENABLE WATCHDOG - [0x29]	12
5.4.6 FIRMWARE MAJOR REV - [0x30]	12
5.4.7 FIRMWARE MINOR REV - [0x31]	13
5.4.8 NO OPERATION - [0x34]	13
5.4.9 GET RESET COUNT - [0x38]	13
5.4.10 CLEAR RESET COUNT & LED - [0x39]	13
5.4.11 TURN ON RELAY #2 - [0x50]	13
5.4.12 TURN OFF RELAY #2 - [0x51]	14
5.4.13 READ THE TEMPERATURE - [0x58]	14
5.4.14 DIAGNOSTIC COMMANDS - [0xC0-0xCF]	14
5.5 WATCHDOG COMMANDS – REVISION C BOARDS	15

5.5.1	READ DIP SWITCH MSB - [0x40]	16
5.5.2	READ DIP SWITCH LSB - [0x41]	17
5.5.3	GET STATUS - [0x44]	17
5.5.4	RELAY #2 ON AT POWER ON - [0x52]	17
5.5.5	RELAY #2 OFF AT POWER ON - [0x53]	18
5.5.6	READ RELAY #2 STATUS - [0x54]	18
5.5.7	SET DELAY - SECONDS - [0x60]	18
5.5.8	SET DELAY - MINUTES - [0x61]	19
5.5.9	SAVE DELAY - SECONDS - [0x64]	19
5.5.10	SAVE DELAY - MINUTES - [0x65]	19
5.5.11	SET TIMEOUT - SECONDS - [0x68]	19
5.5.12	SET TIMEOUT - MINUTES - [0x69]	20
5.5.13	SAVE TIMEOUT - SECONDS - [0x6C]	20
5.5.14	SAVE TIMEOUT - MINUTES - [0x6D]	20
5.5.15	SAVE RESET RELAY PULSE WIDTH - [0x70]	20
5.5.16	SAVE TEMPERATURE OFFSET - [0x74]	21
5.5.17	SAVE USER ID DATA - [0x90 - 97]	21
5.5.18	READ NV DELAY (POD) - [0xA0]	22
5.5.19	READ NV TIMEOUT - [0xA1]	22
5.5.20	READ NV RESET RELAY PULSE WIDTH - [0xA2]	22
5.5.21	READ NV TEMPERATURE OFFSET - [0xA3]	22
5.5.22	READ NV USER ID DATA - [0xB0 - B7]	23
6.	<u>LED OPERATION</u>	24
6.1	TOP LED	24
6.2	BOTTOM LED	24
7.	<u>GETTING PAST THE LOGIN ON WIN95/98</u>	25
8.	<u>WATCHDOG PROGRAMS</u>	26
8.1	WATCHDOG TEST PROGRAM - WINDOWS 9x, ME, 2K & NT	26
8.2	VISUAL BASIC TEST PROGRAM - WINDOWS 9x, ME, 2K & NT	26
9.	<u>APPENDIX A - SPECIFICATIONS</u>	28
10.	<u>APPENDIX B - WARRANTY</u>	29
11.	<u>APPENDIX C - SERVICE AND TECH SUPPORT</u>	30
11.1	CALLING TECH SUPPORT	30
11.2	PRODUCT RETURNS	30

12. APPENDIX D - AGENCY APPROVALS

31

12.1 FCC - CLASS A

31

12.2 CE

31

1. Introduction

The Serial Watchdog is an internal device that is used to monitor a PC in order to ensure maximum system availability. It has the following features:

- Acts as a pass-through serial port with standard PC DB-9 connectors.
- Monitors the PC serial port for control line activity on TxD, DTR, and RTS from the PC.
- Monitors the Ring Indicator (RI) from a MODEM on the serial port for excessive rings without an answer.
- Can be used right from the box without any support programs.
- Has an on-board temp sensor to detect fan failures or other over-temp conditions.
- Also has a Command Mode that allows a user program to exert additional control over the Watchdog.
- Two externally visible LEDs show status of Watchdog.
- Watchdog has a second relay available on an external plug to control other devices such as resetting another PC.
- Programmable power-on delay to allow the PC to complete its initialization sequence.
- Non-Volatile memory to store operating parameters.
- Eight bytes of non-volatile memory reserved for user data to implement simple software protection

2. Operation

This device is designed to monitor PCs used in critical applications such as: File Servers, Voice Mail Systems, ISP systems, industrial applications, etc. The idea is to make sure the PC is always available and running; especially for systems that are not continuously monitored.

When power is applied to the Watchdog, or after a reset of the PC, the Watchdog will wait 2.5 minutes (shorter times allowed in Command Mode) before it arms itself. This allows the PC to complete its reset and initialization sequence. There is a Dip switch option to allow the Watchdog to extend this time for PCs that need additional re-boot time.

Once the Watchdog is ready to arm itself it will check the Dip switches and enable up to three independent operating modes. These modes can ALL be active at once. They are:

- **Command Mode** - Receive commands from PC on serial port and send responses.
- **Monitor Mode** - Monitor RS-232 control lines from the PC serial port for activity.
- **Ring Mode** - Count ring signals from MODEM to detect ring-no-answer conditions.

Additional Dip switches are used to set the timeout period and ring count. If no activity is detected in Command or Monitor Mode by the time the Watchdog timer expires, the PC Watchdog will start its reset sequence on the PC. If the Ring Mode is enabled and an excessive number of rings are detected from a MODEM then the Watchdog will also reset the PC.

The two LEDs on the Watchdog are used for status indication. The top LED provides the arming status of the Watchdog by varying the rate at which the LED flashes. When the Watchdog resets the PC it will turn on the bottom LED and leave it on which provides an indication that at least one Watchdog reset has occurred, possibly more. In Command Mode the PC can turn this LED off and also get a count of the number of resets that have occurred. The bottom LED will also flash (on or off) once per second for a tenth of a second if a Watchdog timer reset event occurred in the prior second.

Note: If you stop your application program or you reset the PC with CTL-ALT-DEL, then be sure to disable the Watchdog by unplugging the reset cable or removing power. Otherwise it may count down and reset your PC at an inopportune time!

3. Installation of Supplied Components

The standard Watchdog package contains the following items:

- This manual (on diskette as a PDF file).
- The Watchdog timer on a standard PC I/O bracket.
- A disk drive “Y” style power cable to power the board.
- A DB-9 to DB-9 serial cable.
- A 3 ½” program diskette.
- A reset cable

3.1 Basic Installation

Perform these steps to install the Watchdog:

- Locate an unused I/O slot in the PC. Remove the blank bracket and install the Watchdog.
- Make sure the Dip switches are set properly before applying power to the Watchdog since it only checks the switches at power up and after each reset of the PC.
- Disconnect the PC reset cable from the motherboard. Plug this cable onto the **J3** header in the upper left corner of the Watchdog board.
- Plug the supplied reset cable onto **J2** on the Watchdog board and plug the other end onto the original reset header on the motherboard.
- Connect the DB-9S end of the serial cable to a COM port on the PC. Connect the other end of the cable (DB-9P) to the **Serial Input** port on the Watchdog.
- *Optional Step. If you are using the pass through mode of the Watchdog then connect your original serial device to the **Serial Output** port on the Watchdog.*

3.2 Secondary Reset Option

If you purchased this option (Part Number: 1122) then you will have the following:

- A PC I/O bracket with a 1/8" stereo jack and two headers on a small circuit board.
- A three conductor cable with 1/8" stereo plugs on each end
- A two conductor reset cable.

The second relay contacts are on the 1/8" stereo jack on the bracket above the LEDs. The two relay contacts are on the inner two contacts of the jack (Tip & Ring). The sleeve of the jack is grounded through its connection to the bracket.

3.2.1 Secondary Reset Option Diagram #1

There are many possibilities for connecting this option. One simple method is shown in the following diagram:

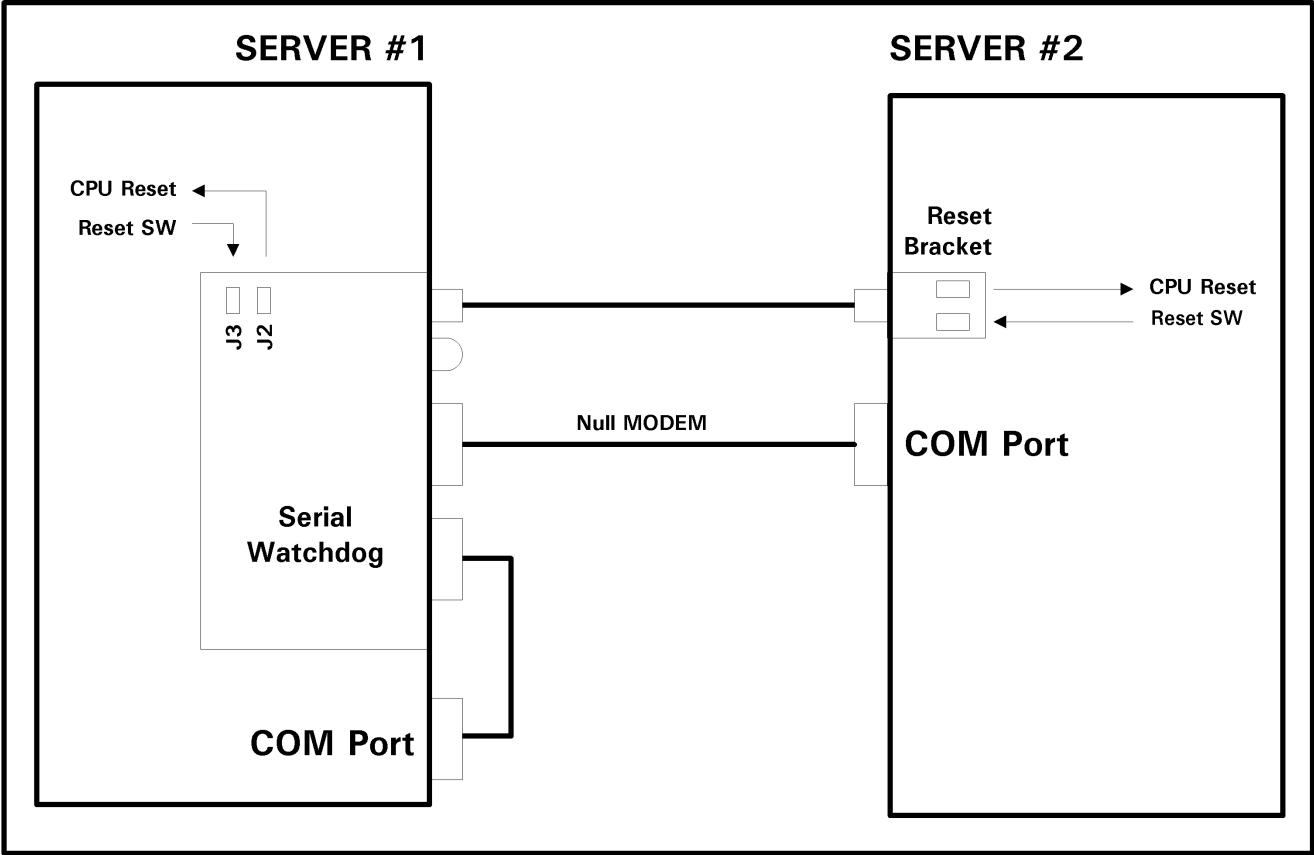

Here we have a master PC with a Watchdog. If it locks up, then its Watchdog card will reset it. If the communications link to the second PC fails as a result of the second PC locking up, then the first PC can reset the second via the external relay and a user program command.

3.2.2 Secondary Reset Option Diagram #2

This diagram shows an even more complex example:

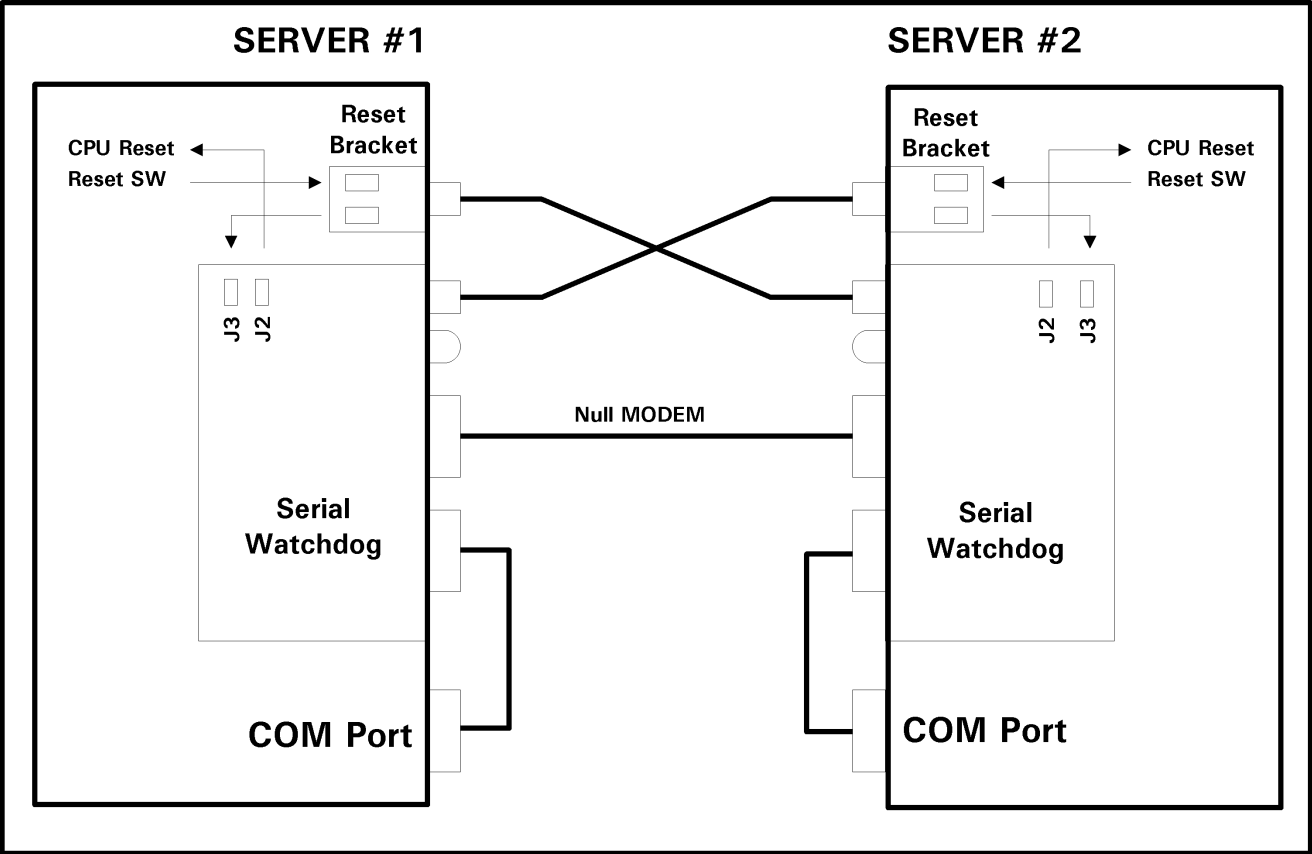

Now both PCs have Watchdog cards to reset them if either one locks up. They also talk to each other through the serial ports and a null MODEM cable. Now either PC can reset the other if it only partially locks ups.

4. Dip Switch Settings

All the switches are read at power up and after each time that the Watchdog resets the PC. A switch that is **DOWN** is **OFF** and a switch that is **UP** is **ON**. The following sections cover the switch options.

4.1 Mode Switches - SW1, SW2 & SW3

These three switches set the operating mode of the Watchdog. If all three of these switches are off then the Watchdog powers up in factory diagnostics mode and will not operate properly!

It is OK for Ring mode and one more of these switches to be on at one time. The Watchdog will support Ring mode and one other mode together.

4.1.1 Monitor Mode - SW1

When this mode is active the Watchdog will monitor the three output control lines on the serial COM port of the PC. The lines are:

- Transmit Data (**TxD**) on Pin 3 of the DB-9.
- Data Terminal Ready (**DTR**) on Pin 4 of the DB-9.
- Request To Send (**RTS**) on Pin 7 of the DB-9.

Any activity on any of these lines will cause the Watchdog to reset its timeout count.

4.1.2 Command Mode - SW2

If this switch is on the Watchdog enters command mode. This requires that the PC send commands to the Watchdog as serial data to make it reset the timeout counter. See the Command Mode section for further information. This mode will require the user to write support software into their application program.

4.1.3 Ring Mode - SW3

If this switch is on the Watchdog will count pulses on the Ring Indicator (**RI**) pin 9 of the cable from the MODEM. If the number of rings exceed a preset number (set by switches 6-8) then the Watchdog will reset the PC. If the number of rings is lower, followed by an idle time of about 15 seconds, then the Watchdog will reset the ring counter based on the settings of switches 6-8.

If this is the only switch of three that is on then the Watchdog will not use the timeout mode at all. It will only function as a ring-no-answer Watchdog.

4.2 Power On Delay (POD) - SW4

After a power up or a PC reset the Watchdog normally waits 2.5 minutes to allow the PC to re-boot. This time can be shortened in Command Mode. Sometimes the PC will require more than 2.5 minutes to complete the re-boot, which can be accommodated by turning on this switch.

In Monitor or Command Mode the Watchdog will delay starting the timeout counter until it "sees" the first activity in either of these modes. In the Ring mode it will wait until the DTR line to MODEM goes active. When DTR goes active the bottom LED will flash once.

Note: If the PC does not complete the re-boot process correctly, then this option can disable the Watchdog as well as leave the PC frozen.

4.3 Over-temp Reset - SW5

If this switch is on then the Watchdog will reset and hold the reset on a PC during an over-temp condition. The first trip point is **46°C** (115°F) at which point the buzzer will start to sound. The second trip point where the Watchdog can reset the PC is **56°C** (133°F). If the Watchdog resets the PC, it will remain in reset until the temperature drops back below **50°C** (122°F). A software command allows you to increase these trip points by adding a fixed offset up to 31°C.

4.4 Timeout Count / Ring Count - SW6, SW7, & SW8

These switches set the delay time until the Watchdog resets the PC. As long as the Watchdog is getting activity in Command or Monitor Mode then it will reset the timeout counter with these values. These switches also set the ring counts in Ring Mode for ring-no-answer detection. The settings and times are:

Switches 6-8	Delay Time	Ring Count
OFF-OFF-OFF	5 Seconds	2
OFF-OFF- ON	10 Seconds	3
OFF- ON-OFF	30 Seconds	5
OFF- ON- ON	1 Minute	9
ON-OFF-OFF	10 Minutes	9
ON-OFF- ON	30 Minutes	9
ON- ON-OFF	1 Hour	9
ON- ON- ON	2 Hour	9

5. Command Mode Operation

The Watchdog is designed to monitor the Transmit Data (**TxD**) line from the PC and respond to commands from the PC when the Command Mode is enabled. The Watchdog is wire-ORed into the receive data line from an external device such as a MODEM to allow it to send back responses. In a lot of cases the PC may be able to communicate with a MODEM by activating Data Terminal Ready (**DTR**) and using standard **AT** commands. The PC should be able to communicate with the Watchdog by dropping **DTR** and sending commands to the Watchdog. The MODEM should ignore the Watchdog commands since **DTR** is inactive and the Watchdog commands do not start with the **AT** sequence.

5.1 COM Port Settings

The Watchdog requires that the COM port on the PC be set to 1200 Baud, 8 Data Bits, No Parity Bit, and 2 **Stop Bits**. The requirement for 2 stop bits is important because the processor uses the idle time between characters to process input data and take care of other processing tasks.

5.2 Command Formats

The Watchdog looks for a five (5) byte command packet that includes a checksum. This is done to help insure that MODEM data is not accidentally interpreted as commands. The format is:

[0x01] [0x57] [0x84] [cc] [ss]

- The first three bytes are always the fixed hex values.
- **cc** - This is the actual command byte described later.
- **ss** - This is a simple checksum. It is calculated by adding the prior 4 bytes and subtracting the value from 0x00. When the Watchdog receives the data and sums all 5 bytes (including checksum) it should get the byte (unsigned char) result 0x00.

Example: [0x01] [0x57] [0x84] [0x34] [0xF0] - NOP command

5.3 Response Format

Important Note:

Any commands that are received OK (except RESET) will cause the Watchdog to reset the timeout counter.

The response data from the board is a four (4) byte packet that does not have a checksum. The format is:

[0x57] [0x84] [rr] [0x0d]

- The first two bytes are always the fixed hex values.
- **rr** - This is the response data byte.
- The last byte is an ASCII Carriage Return [0x0d].

The responses can be one of the following:

- [0x06] - ACK - Command received and processed OK but no response required.
- [0x15] - NAK1 - Command had checksum error.
- [0x16] - NAK2 - Invalid command.
- [0x20-0xFF] - Responses from commands where required. All responses will have 0x20 (except the temp command – 0x58) added so that they do not look like ASCII control codes.

5.4 Watchdog Commands – Revision B Boards

See Section 5.5 for new commands that were added for revision C (and higher) Internal Serial PC Watchdogs.

The following sections cover the commands that the Watchdog will accept and the return values if required. This table gives a quick overview of the command numbers.

Command	Description
0x20	Reset PC Now
0x21	Reset PC in 10 Seconds
0x24	Arm Watchdog Now
0x28	Disable Watchdog
0x29	Enable Watchdog
0x30	Firmware Major Rev
0x31	Firmware Minor Rev
0x34	No Operation
0x38	Get Reset Count
0x39	Clear Reset Count & LED
0x50	Turn on Relay #2
0x51	Turn off Relay #2
0x58	Read the Temperature

5.4.1 Reset PC Now - [0x20]

This Command will reset the PC within 1 - 2 seconds after the response has been sent.

Response: None required, will be an ACK - [0x06].

5.4.2 Reset PC in 10 Seconds - [0x21]

This Command will reset the PC within 10 - 12 seconds after the response has been sent.

Response: None required, will be an ACK - [0x06].

5.4.3 Override Power-On-Delay - [0x24]

This Command will make the Watchdog terminate the 2.5-minute power on delay and arm itself after a power up or PC reset. If the Power-on-Delay Dip switch is set (switch number 4) then you will still need to send at least one command (such as **No Operation – 0x34**) in order to arm the board. *Do not send this command more than one time!*

Response: 0x20 - command processed OK.
0x21 - Watchdog was already armed - command ignored.

5.4.4 Disable Watchdog - [0x28]

This Command will disable the Watchdog. *USE IT CAREFULLY!*

Response: None required, will be an ACK - [0x06].

5.4.5 Enable Watchdog - [0x29]

This Command will enable the Watchdog and is used to terminate a *Disable Watchdog* command.

Response: None required, will be an ACK - [0x06].

5.4.6 Firmware Major Rev - [0x30]

This Command returns the major revision of the firmware.

Response: A value from 0x20 - 0x29. Subtract 0x20 to get the value in hex.

Ex: 0x22 - 0x20 = 2 -> Rev **2**.xx

5.4.7 Firmware Minor Rev - [0x31]

This Command returns the minor revision of the firmware.

Response: A value from 0x20 - 0x83. Subtract 0x20 to get the value in hex.

Ex: $0x43 - 0x20 = 0x23 = 35 \rightarrow$ Rev x.35

5.4.8 No Operation - [0x34]

This Command is only used to reset the timeout counter and verify communications.

Response: None required, will be an ACK - [0x06].

5.4.9 Get Reset Count - [0x38]

This Command returns the number of times the Watchdog has reset the PC. The counter stops at 128 (0x80).

Response: A value from 0x20 - 0xA0. Subtract 0x20 to get the value in hex.

5.4.10 Clear Reset Count & LED - [0x39]

This Command clears the reset counter back to zero and turns off the bottom LED.

Response: None required, will be an ACK - [0x06].

5.4.11 Turn On Relay #2 - [0x50]

This command turns on the second relay whose contacts are available on the 1/8" Stereo jack above the two LEDs.

Response: None required, will be an ACK - [0x06].

5.4.12 Turn Off Relay #2 - [0x51]

This command turns off the second relay.

Response: None required, will be an ACK - [0x06].

5.4.13 Read the Temperature - [0x58]

This command returns the temperature in degrees Celsius. It can return values from -32° to $+127^{\circ}\text{C}$. To accommodate this range the result returned also has an additional 0x20 added to value. Note: After subtracting the total offset you will have a *signed* byte value.

Response: A value from 0x20 - 0xbf. Subtract 0x40 to get the signed value in hex.

Ex: $0x53 - 0x40 = 0x13 = 19^{\circ}\text{C}$

Ex: $0x35 - 0x40 = 0xf5 = -11^{\circ}\text{C}$

5.4.14 Diagnostic Commands - [0xC0-0xCF]

Commands in this range are reserved for diagnostic production tests. They may produce undesirable results.

5.5 Watchdog Commands – Revision C Boards

Internal Serial PC Watchdogs that have a PCB **Revision** of C, or higher, will accept new commands. Revision C boards will have a firmware version of 2.00 or higher. Some of these commands allow the user to save configuration data in an on-board non-volatile memory to override some of the switch settings.

The new Watchdog looks for six (6) byte command packets as well. The format is:

[0x01] [0x57] [0x85] [cc] [vv] [ss]

- The first three bytes are always the fixed hex values (note the 0x85).
- **cc** - This is the actual command byte described later.
- **vv** – This is a command value such a new delay time.
- **ss** - This is a simple checksum. It is calculated by adding the prior 5 bytes and subtracting the value from 0x00. When the Watchdog receives the data and sums all 6 bytes (including checksum) it should get the byte (unsigned char) result 0x00.

Example: [0x01] [0x57] [0x85] [0x60] [0x50] [0x73] - Set Delay Seconds

This table gives a quick overview of the new command numbers. *This table has two new sections called: **6 BYTE** & **NV**. If the **6 BYTE** value is: **YES** then it is a 6-byte command packet. If the **NV** value is: **YES** then it is a command that writes or reads the non-volatile memory. Allow an additional 100mS for the board to respond to these commands.*

Command	Description	6 BYTE	NV
0x40	Read DIP Switch MSB	No	No
0x41	Read DIP Switch LSB	No	No
0x44	Get Status	No	No
0x52	Relay #2 ON at Power On	No	Yes
0x53	Relay #2 OFF at Power On	No	Yes
0x54	Read Relay #2 Status	No	Yes
0x60	Set Delay (POD) - Seconds	Yes	No
0x61	Set Delay (POD) - Minutes	Yes	No
0x64	Save Delay (POD) Seconds	Yes	Yes
0x65	Save Delay (POD) Minutes	Yes	Yes
0x68	Set Timeout - Seconds	Yes	No
0x69	Set Timeout - Minutes	Yes	No
0x6C	Save Timeout Seconds	Yes	Yes
0x6D	Save Timeout Minute	Yes	Yes
0x70	Save Reset Relay Pulse Width	Yes	Yes
0x74	Save Temperature Offset	Yes	Yes
0x90-97	Save User ID Data	Yes	Yes
0xA0	Read NV Delay (POD)	No	Yes
0xA1	Read NV Timeout	No	Yes
0xA2	Read NV Reset Relay Pulse Width	No	Yes
0xA3	Read NV Temperature Offset	No	Yes
0xB0-B7	Read NV User ID Data	No	Yes

The following sections cover the new commands that the Watchdog will accept and the return values if required.

5.5.1 Read DIP Switch MSB - [0x40]

This Command will return the settings of the upper nibble of DIP Switch settings with 0x20 added. The values will range from 0x20 to 0x2F. A switch that is on will read as a one (1).

Response: Values will range from 0x20 to 0x2F.

5.5.2 Read DIP Switch LSB - [0x41]

This Command will return the settings of the lower nibble of DIP Switch settings with 0x20 added. The values will range from 0x20 to 0x2F. A switch that is on will read as a one (1).

Response: Values will range from 0x20 to 0x2F.

5.5.3 Get Status - [0x44]

This command returns two (2) bits of data in D0 and D1 of the response. There is also an offset of 0x20 added to the response. The bits are defined as follows:

D0: One (1) means that the non-volatile memory was OK at power up.

D1: One (1) means that temperature monitor IC was OK at power up.

Response: Values will range from 0x20 to 0x23.

5.5.4 Relay #2 ON at Power On - [0x52]

This Command allows you to set the mode of Relay #2 each time the board powers up. This relay's contacts are available on the 1/8" Stereo jack above the two LEDs. If you send this command the board will store this in non-volatile memory and turn on the relay each time power is applied to the PC. Use command 0x50 (section 5.4.11) if you want to turn on the relay immediately.

Response: None required, will be an ACK - [0x06].

5.5.5 Relay #2 OFF at Power On - [0x53]

This Command allows you to set the mode of Relay #2 each time the board powers up. If you send this command the board will store this in non-volatile memory and leave the relay off each time power is applied to the PC. Use command 0x51 (section 5.4.12) if you want to turn off the relay immediately.

Response: None required, will be an ACK - [0x06].

5.5.6 Read Relay #2 Status - [0x54]

This command returns two (2) bits of data in D0 and D1 of the response. There is also an offset of 0x20 added to the response. The bits are defined as follows:

D0: One (1) means that Relay #2 is currently ON.

D1: One (1) means that Relay #2 is set for ON at power up.

Response: Values will range from 0x20 to 0x23.

5.5.7 Set Delay - Seconds - [0x60]

When the board powers up, or after it resets the PC it will normally wait 2.5 minutes (Power-On-Delay - **POD**) before it arms itself. It may wait a shorter or longer time if a value has been set in the non-volatile memory using a Save command. If the board is still in the power on delay mode when it receives this command then it will set the power on delay to the new value. This enables the user to shorten or lengthen the current delay.

The value passed in the value byte (**vv**) allows a range of 0x01 to 0xFF or delays in the range 0x01 to 0xFF seconds. Note that a value of zero will actually be one second.

Response: 0x20 - command processed OK.

0x21 - Watchdog was already armed - command ignored.

5.5.8 Set Delay - Minutes - [0x61]

This works just like the prior command (0x60) except it allows delays to be in minutes. Note that a value of zero will actually be one minute.

Response: 0x20 - command processed OK.
0x21 - Watchdog was already armed - command ignored.

5.5.9 Save Delay - Seconds - [0x64]

This command saves the new value in non-volatile memory for future use. If the value data (**vv**) is 0x00, which is a delay of zero, then the non-volatile value will be cleared and the board will revert back to the 2.5 minute delay at the next re-boot cycle.

Response: None required, will be an ACK - [0x06].

5.5.10 Save Delay - Minutes - [0x65]

This works just like the prior command (0x60) except it allows delays to be in minutes.

Response: None required, will be an ACK - [0x06].

5.5.11 Set Timeout - Seconds - [0x68]

When the board starts it will use the DIP switches to get the timeout value or it may get this value from the non-volatile memory. This command enables the user to shorten or lengthen the current timeout value.

The value passed in the value byte (**vv**) should be in the range of 0x01 to 0xFF or timeouts in the range 0x01 to 0xFF seconds. Note that a value of zero will cause the board to revert to the value in non-volatile memory first if it is present, or the DIP switch setting.

Response: None required, will be an ACK - [0x06].

5.5.12 Set Timeout - Minutes - [0x69]

This works just like the prior command (0x68) except it allows timeouts to be in minutes.

Response: None required, will be an ACK - [0x06].

5.5.13 Save Timeout - Seconds - [0x6C]

This command saves the new value in non-volatile memory for future use. If the value data (**vv**) is 0x00, which is a delay of zero (0x00), then the non-volatile value will be cleared and the board will revert back to the timeout setting on the DIP switches. The new non-volatile time will be used the next time the board is “tickled”.

Response: None required, will be an ACK - [0x06].

5.5.14 Save Timeout - Minutes - [0x6D]

This works just like the prior command (0x6C) except it allows delays to be in minutes.

Response: None required, will be an ACK - [0x06].

5.5.15 Save Reset Relay Pulse Width - [0x70]

The default mode for the Watchdog is to pulse a reset relay (which simulates pushing the reset button) for 3 seconds. This value works for most computers, however some machines may require longer or shorter values. This command allows you to tailor the pulse time by selecting a delay in 50mS tics. This value is stored in the non-volatile memory.

The value passed in the value byte (**vv**) should in the range of 0x01 to 0xFF or pulses in the range 50mS to 12.75 seconds.. A value of zero (0x00) allows you to return to the default 3-second pulse. The new time will be activated at the next re-boot of the PC. Be careful using low times (1 or 2 tics) since these may be too short to generate valid resets on the PC.

Response: None required, will be an ACK - [0x06].

5.5.16 Save Temperature Offset - [0x74]

This command permits an increase in the temperature trip points on the watchdog board. The command allows you to set the offsets up to 31 (0x1f). If the offset is used then it will be active every time the PC powers up.

The offset here is in degrees C and can range from 0x00 to 0x1F. Values higher will be corrected modulo 32. A value of zero causes the board to go back to using the fixed trip values.

Response: None required, will be an ACK - [0x06].

5.5.17 Save User ID Data - [0x90 - 97]

Eight (8) bytes of the non-volatile memory have been reserved for the user to store their own ID data. Commands 0x90 to 0x97 store the user ID bytes in locations 0 to 7 respectively.

These bytes could have many uses with one of them being a software security mechanism. A user could make their software refuse to run unless there was a watchdog board in the system with the correct code in the memory.

Response: None required, will be an ACK - [0x06].

5.5.18 Read NV Delay (POD) - [0xA0]

When you save a Power-On-Delay (POD) in the non-volatile memory the time is actually stored and used internally as a 16-bit value. In order to read back the value you will need to issue this command 4 times. Each read will return 4 bits of the value starting with the MSB. These four bits will have an offset added to them that will start at 0x20 and increase by 0x10 for each read to keep in sync. If another command is sent before you complete the 4 reads, then the next time you send this command it will start over.

Ex: Time saved was 7 minutes = 420 seconds = 0x01A4 saved.

Read #1 = 0x20 | #2 = 0x31 | #3 = 0x4A | #4 = 0x54

Response: Values will range from 0x20 to 0x5F.

5.5.19 Read NV Timeout - [0xA1]

This command works just like command 0xA0 described in the prior section except it returns the watchdog timeout value.

Response: Values will range from 0x20 to 0x5F.

5.5.20 Read NV Reset Relay Pulse Width - [0xA2]

When you save a reset relay pulse width in the non-volatile memory the time is stored as an 8-bit value This command works just like command 0xA0 described in the prior section except it returns only 2 nibbles (4 bits each) of data.

Response: Values will range from 0x20 to 0x3F.

5.5.21 Read NV Temperature Offset - [0xA3]

This command works just like command 0xA2 described in the prior section except it returns the temperature offset value.

Response: Values will range from 0x20 to 0x3F.

5.5.22 Read NV User ID Data - [0xB0 - B7]

This command works just like command 0xA2 described in the prior section except it returns the user ID data bytes. Commands 0xB0 to 0xB7 return the user ID bytes in locations 0 to 7 respectively.

Response: Values will range from 0x20 to 0x3F.

6. LED Operation

The two LEDs on the Watchdog are used for system status.

6.1 Top LED

During the 2.5 minutes that the Watchdog waits after power-up or after it resets the PC it will flash this LED at a 1 second rate (1 second on, 1 second off). Once the Watchdog has armed itself it will flash the LED at a 350mS rate. In the last 3 seconds before the Watchdog resets the PC it will flash this LED rapidly at a 100mS rate.

6.2 Bottom LED

After the first time the Watchdog resets the PC it will light this LED as a visible indicator that at least one reset (maybe more) has occurred. This LED can be turned off by cycling power on the Watchdog, pushing the PC reset button, or via Command Mode.

This LED will also flash once per second for 100mS to indicate that activity has been detected in Command or Monitor Mode and for each ring pulse from the MODEM in Ring Mode. This flash will be the inverse of the LED state at the time.

7. Getting past the Login on Win95/98 & ME

When Windows boots it will stop with a login screen that prompts for a user name and password. It will hang at this point indefinitely until the data is entered or you click the **Cancel** button. If the Watchdog has rebooted your PC then it would hang at this point.

Microsoft has solved this problem with a set of utilities called Powertoy that can be downloaded from their site at: <http://www.microsoft.com/>. One of the utilities in the package is called **TWEAKUI** that installs in the *Control Panel* under *My Computer*. When you run the utility there will be a tab called Network that allows you to specify an auto login and provide the computer name and password.

8. Watchdog Programs

There are some programs on the enclosed diskette for testing and configuring the Watchdog board. Some of these programs use switches to determine which user port to check to get status or perform commands. All the source and other support files are supplied for each program which should make it easier to modify them for user's special requirements. *Check the diskette for other programs that have been added since this manual was written.*

8.1 Watchdog Test Program - Windows 9x, ME, 2K & NT

This program is used to test and configure the Serial Watchdog. This program is a console application written in 32 bit code. The name of this program is: **W32ConApp.exe** and it is in the \ **W32ConApp** directory on the diskette.

When this program runs it will prompt the user for a command to send the Watchdog and then display the response. You must have the Command Mode DIP switch turned on for this option to work.

The switch for this program is:

/p# - Where # = 1-4 for COM1-4 (default is COM1)

EX: C:>w32conapp /p2

8.2 Visual Basic Test Program - Windows 9x, ME, 2K & NT

This program and files are in the **VB32_Pgm** directory on the diskette. When this program runs it will allow you to choose the serial port and test the Watchdog by sending a revision command to display the firmware version. It also has a second screen that allows you to display and modify the non-volatile memory contents. You can also select RUN which will minimize the program and make it toggle DTR to keep the Watchdog from resetting the PC. The Watchdog must be in monitor mode.

You can put this program into a startup group with two command line switches that must be present. The switches for this program are:

/p# - Where # = 1-4 for COM1-4 (default is COM1)

/m - start minimized

EX: Ser-WDog /p2 /m

9. Appendix A - Specifications

Power Requirements: +5 VDC - 200mA Max.

Environmental: -20 - 65°C Operating
-20 - 70°C Storage
5-95% Relative Humidity - Non Condensing

MTBF: 500,000 Hours

TEMP: $\pm 1.5^{\circ}\text{C}$

Note: You may find that the board will continue to work just fine beyond the specified temperature limits, especially at lower temperatures. These temperature limits are those specified by the manufacturers of the integrated circuits.

Relay #2: SPST (1 form a) - 48V @ 0.5A max

This relay has contacts that are available on the 1/8" Stereo jack above the two LEDs. The tip of the plug is one relay contact and the ring (second terminal on the plug) is the other relay contact. The major or last conductor (sleeve) of the plug is ground and is connected to the PC bracket.

10. Appendix B - Warranty

Berkshire Products, Inc. warrants to the original consumer or other end user purchaser that this product is free from defects in materials or workmanship for a period of one (1) year from the date of purchase. During the warranty period, and upon proof of purchase, the product will be repaired or replaced (with the same or functionally equivalent model) at our option, without charge for either parts or labor.

This warranty does not apply to defects due directly or indirectly to misuse, abuse, negligence, accident, repairs or alterations made by the customer or another party.

UNDER NO CIRCUMSTANCES WILL BERKSHIRE PRODUCTS, Inc. BE LIABLE IN ANY WAY TO ANY PURCHASER FOR DAMAGES, LOST REVENUE, LOST WAGES, OR ANY OTHER INCIDENTAL OR CONSEQUENTIAL DAMAGES ARISING OUT OF THE USE OR INABILITY TO USE THIS PRODUCT.

Berkshire Products, Inc. reserves the right to make modifications in this product without prior notification.

11. Appendix C - Service and Tech Support

We are available to help you with your questions and problems that you may have with our product. Our technical support is available:

Monday through Friday (except holidays)
8:30 AM to 5:00 PM (Eastern Time)
770-271-0088

FAX us at: 770-932-0082
Email: support@berkprod.com

11.1 Calling Tech Support

To help our tech support personnel with your problem, please try to have the following information ready:

- Type of PC
- Type of operating system and version
- Clear description of the problem

11.2 Product Returns

Please call our tech support personnel before returning a product. Many times the problem can be corrected over the phone. If the tech support representative determines that your product must be returned, they will assign you a **RMA #**.

Package the product in a secure container and return it to us freight prepaid. We will not accept COD freight charges! Indicate the **RMA #** on the package or shipping label.

If the repairs are done under warranty the unit will be returned UPS ground and we will pay the freight charges. If you prefer Federal Express, please provide your Federal Express account number.

If your unit is out of warranty, repairs and shipping will be charged COD or other method established in advance.

12. Appendix D - Agency Approvals

The PC Watchdog meets the following agency approvals.

12.1 FCC - Class A

This equipment generates and uses radio frequency energy and if not installed and used properly, that is in strict adherence with the manufacturer's instructions, may cause interference to radio and television reception. It has been tested and found to comply with the limits for a Class A computing device in accordance with the specifications in Subpart J of Part 15 of FCC rules, which are designed to provide reasonable protection against such interference in a commercial installation. If this equipment does cause interference to radio or television reception, which can be determined by turning the equipment off and on, the user is encouraged to try to correct the interference by one or more of the following measures:

- Reorient the receiving antenna.
- Relocate the computer with respect to the receiver.
- Move the computer away from the receiver.
- Plug the computer into a different outlet so that the computer and receiver are on different branch circuits.
- Consult the dealer or an experienced radio/TV technician for help.

12.2 CE

The Internal Serial PC Watchdog has successfully passed all appropriate tests that are necessary for its certification under EMC directive 89/336/EEC.